



268
HANDHELD CASES

292
UNIVERSAL
ENCLOSURES

318
HEAVY DUTY
AND ELECTRICAL
ENCLOSURES

342
DESKTOP AND
INSTRUMENT
CASES

348
DEVELOPMENT
BOARD
ENCLOSURES

367
ROOM SENSOR
ENCLOSURES

370
CUSTOM SIZED
ENCLOSURES

7570 series Curved style enclosures

No design charges - No tooling

Simply provide your internal dimensions for a free quotation

Product overview

Curved style enclosures manufactured in **custom** sizes to fit your PCB assembly and components.

Features

- Four part end panel design
- Snap-together design
- Manufactured to your custom specifications
- Various material colour and specification options
- Manufactured to order on short lead-times

Options

- Manufactured in either HIPS UL94-HB, ABS acrylic capped or listed ABS UL94-V0
- CNC milling (holes, cut-outs, vents, pockets, pillars, windows)
- Screen printing/membranes/overlays

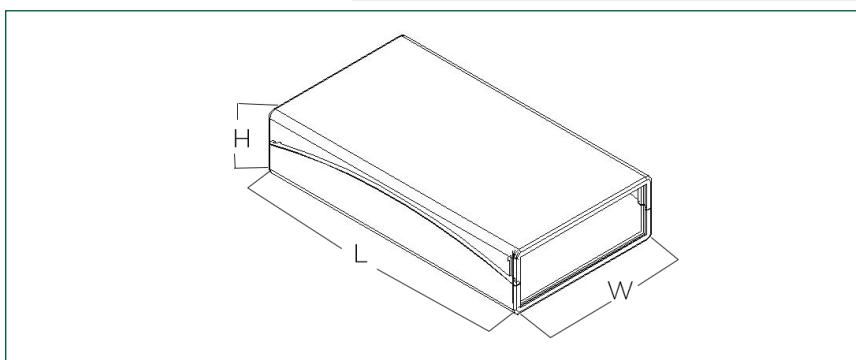
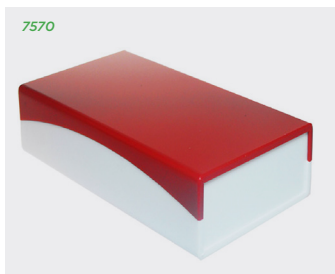

PART NO.	LENGTH (INT)	WIDTH (INT)	HEIGHT (INT)	LENGTH (EXT)	WIDTH (EXT)	HEIGHT (EXT)
7571	130.1mm	71mm	25mm	138.5mm	77mm	31mm
7572	100.1mm	121mm	25mm	108.5mm	127mm	31mm
7573	150.1mm	141mm	40mm	158.5mm	147mm	46mm
7574	175.1mm	151mm	50mm	183.5mm	157mm	56mm
7575	180.1mm	171mm	55mm	188.5mm	177mm	61mm
Custom size	Please advise dimensions					

Available in a range of colours:



KEY FEATURES

Snap together case | Four piece construction | Aesthetic design

